

# ELECRAFT® K3

## HIGH-PERFORMANCE 160 – 6 METER TRANSCEIVER

### KIO3B INTERFACE OPTION INSTALLATION INSTRUCTIONS

Revision A1, December 29, 2015  
E740280

Copyright © 2015, Elecraft, Inc.

All Rights Reserved

# Contents

Introduction.....	3
Preparing for Installation .....	3
Check K3 Firmware Version.....	3
Anti Static Protection Required.....	3
Tools Required .....	4
Parts Included.....	4
Installation Procedure .....	5
Removing the Top Cover .....	5
Initial Setup.....	12
Computer Interface .....	12
USB Computer Interface.....	12
Forcing a Firmware Download Using the USB Interface .....	13
RS232 Computer Interface.....	13
P3 Panadapter Interface .....	13
Monitoring RS232 Data.....	13
Customer Service and Support .....	15
Technical Assistance.....	15
Repair / Alignment Service.....	15
Appendix A – K144XV Cabling .....	16



Elecraft manuals with color images may be downloaded from  
[www.elecraft.com](http://www.elecraft.com).

# Introduction

The KIO3B upgrade kit (KIO3BUPKT) consists of three pc board modules, the KIO3 main board, the audio board and the digital board. The audio and digital boards plug into the main board. All audio and digital input and output signals are routed through the KIO3B.

A USB port is provided for a single-cable solution for most PC interface needs including control and line-level audio input and output. The KIO3B module also digitizes audio routed to the USB port, eliminating the need for a computer sound card and associated cables. RTS or DTR signals for PTT and KEY inputs are available at the USB and RS232 port to support logging or control programs using these signals for controlling transmit/receive switching or CW keying.

The RJ45 connector provides an RS232 interface and communicates with the Elecraft P3 Panadapter.

The DE15 accessory connector provided on the original KIO3 is included for external band decoders (such as the Elecraft KRC2), transverters such as the Elecraft XV series and similar devices. The accessory connector is also used for direct FSK or PSK signaling.

The audio board provides the same three analog interfaces as the original: stereo headphone, stereo speaker and a transformer isolated line output. It also has monaural microphone and isolated line inputs. Bias for an electret microphone can be provided at the microphone input using the K3 menu. The analog inputs and outputs are available even when the USB interface is being used.

## Preparing for Installation

### Check K3 Firmware Version

The KIO3BUPKT requires firmware level 5.26 or above be installed in your K3:

- Connect your K3 to power and tap **POWER** to turn it on.
- Hold **CONFIG**. The firmware version will be displayed on the LCD.
- If needed update your firmware as described in your K3 Owner's manual.

### Anti Static Protection Required

We strongly recommend you take the following anti-static precautions (listed in order of importance) to avoid ESD (Electro Static Discharge) damage:

- Leave ESD-sensitive parts in their anti-static packaging until you install them. Parts which are especially ESD-sensitive are identified in the parts list and in the assembly procedures.
- Wear a conductive wrist strap with a series 1-megohm resistor. If you do not have a wrist strap, touch a bare metal ground briefly before touching any sensitive parts to discharge your body. Do this frequently while you are working. You can collect a destructive static charge on your body just sitting at the work bench.

### **WARNING**

**DO NOT attach a ground directly to yourself without a current-limiting resistor as this poses a serious shock hazard. A wrist strap must include a 1-megohm resistor to limit the current flow. If you choose to touch an unpainted, metal ground to discharge yourself, do it only when you are not touching any live circuits with your other hand or any part of your body.**









- Use a grounded anti-static mat on your work bench.
- No soldering is required but if you choose to use a soldering iron for any reason, be sure your iron has an ESD-safe grounded tip tied to the same common ground used by your mat or wrist strap.

## Tools Required

1. #0 and #1 size Phillips screwdrivers. To avoid damaging screws and nuts, a power screwdriver is *not* recommended. Use the screwdriver that best fits the screw in each step.
2. Wrench to remove jack screw nuts on the K3 back panel. A 3/16” nut driver is recommended.
3. Small needle-nose pliers or tweezers to position small parts.
4. Soft cloth or clean, soft static dissipating pad to lay cabinet panels on to avoid scratching.

## Parts Included

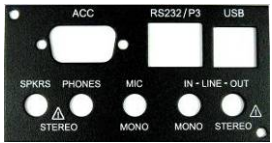
The following parts should be included in your kit. Check to ensure you have them all. If any parts are damaged or missing, contact Elecraft for replacements (see *Customer Service and Support*, page 15).

ILLUSTRATION	DESCRIPTION	QTY.	ELECRAFT PART NO.
	KIO3B Main Board  <b>ESD Sensitive.</b>	1	E850645
	Digital I/O Board  <b>ESD Sensitive.</b>	1	E850646
	Audio I/O Board  <b>ESD Sensitive.</b>	1	E850647
	KIO3B Digital I/O Panel	1	E100558SS
	Jackscrew Nut, 4-40 Note: The jackscrew nuts may be mounted on the DB-15 connector on the KIO3B Digital I/O Board.	2	E700078

Continued on next page

	Screw, 4-40, 1/4" (6.4 mm) Black, Pan Head	2	E700174
	Lock Washer #4 Split	2	E700004
	RJ-45 to DE-9S	1	E980297
	USB A-B Cable	1	E850720

## Installation Procedure

### Removing the Top Cover

Disconnect power and all cables from your K3.

Remove the nine screws to free the top cover as shown in Figure 1. After the cover is open, lift it gently to reach the speaker wire connector. Unplug the speaker. If the K144XV is installed, slip the connector under the stiffener at the depression in the cover of the K144XV module (see Figure 12 on page 11). Set the top cover aside in a safe place.

**⚠ Whenever you remove screws from a panel, if one screw seems too tight to loosen without damaging it, first loosen the other screws then try again. Sometimes one screw binds in its hole when the other screws are tightened.**

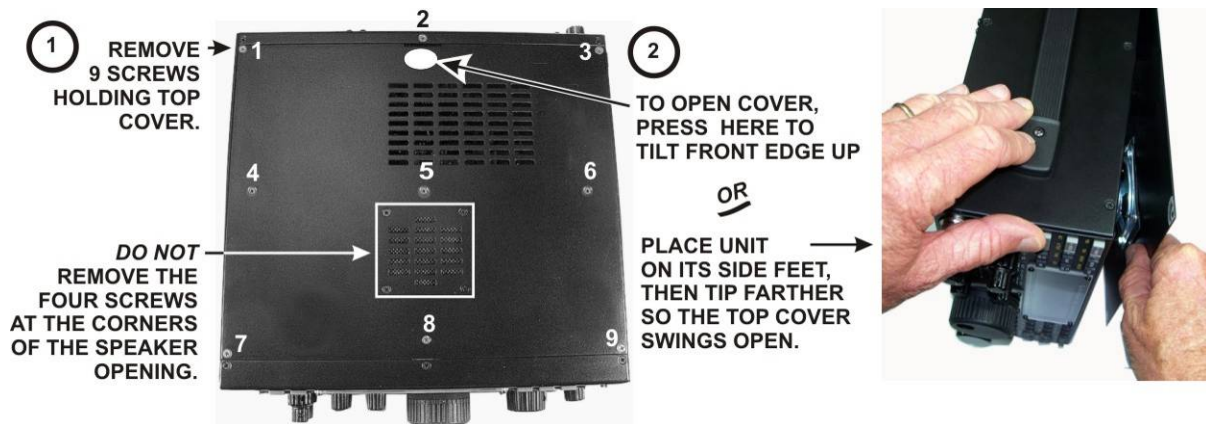

Figure 1. Removing K3 Top Cover.

**⚠ CAUTION:** Touch an unpainted metal ground or wear a grounded wrist strap before touching components or circuit boards inside the K3. See *Anti Static Protection Required* on page 3 for more information.

If you have the K144XV module installed, disconnect the power and TMP cables from the K144XV module.

**⚠ CAUTION:** The TMP connectors are friction fit and pull straight out. Do not pull on the coax cables or you may pull a cable out of its connector. Use your needle-nose pliers to grasp the metal part of the connector visible outside of the K144XV enclosure and pull it straight out.

Remove the seven screws shown in Figure 2 to free the panel and lift the panel off of the K3. Note that Screw 1 is not the screw through the side panel, but is the screw through the lip at the top of the rear panel. This will free the 2D fastener inside to come off with the side panel, which will make removing the existing KIO3 board easier, especially if you have the KRX3 sub receiver installed. If the K144XV 2-meter option is installed carefully shift the panel as needed for the K144XV module to clear the chassis stiffener bar.

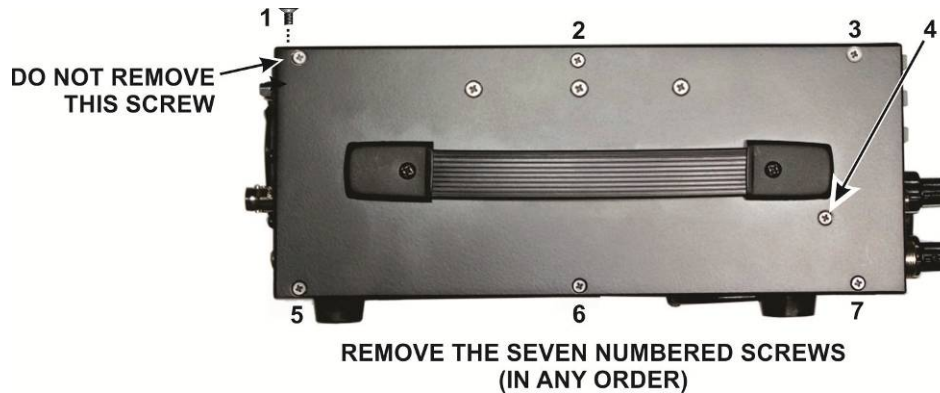

Figure 2. Removing the K3 Left Side Panel.

Remove the rear panel cover over the KIO3 (see Figure 3)



Figure 3. Removing the KIO3 Rear Panel Cover.

Unplug the digital I/O board from the KIO3 main board (see Figure 4). Set the digital I/O board aside. We recommend that you store the boards in the ESD-safe envelopes the new boards came in as you replace them.

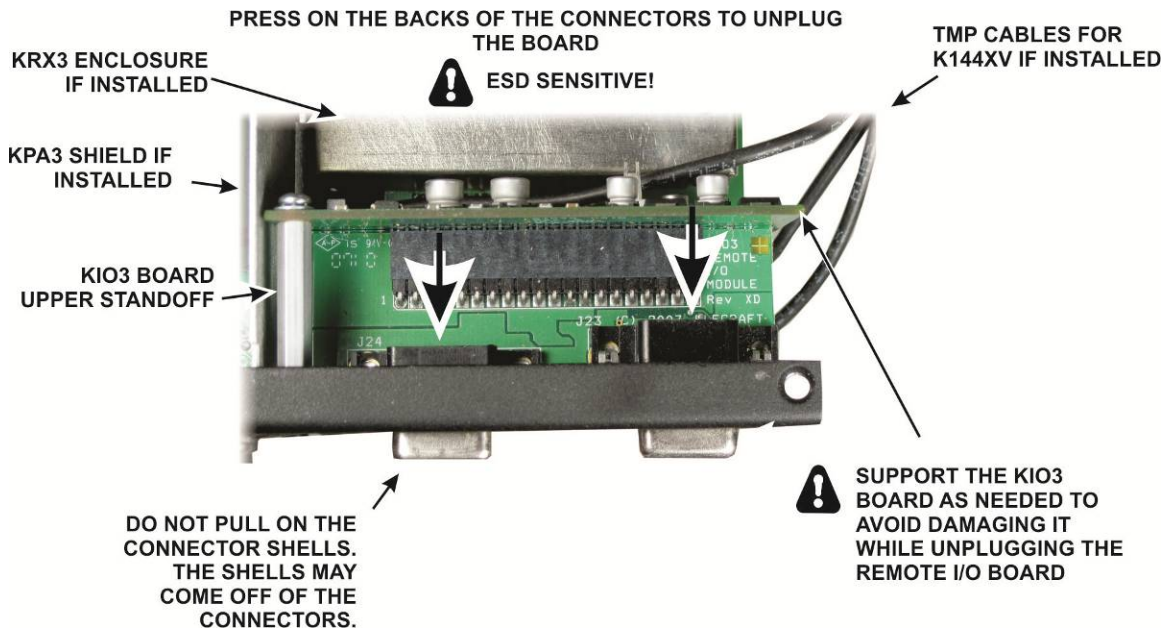

Figure 4. Removing the Remote I/O Board.

Remove the KIO3 board upper standoff (see Figure 4). Take care not to lose the screw or lock washer inside the K3. You can temporarily stand the K3 on the open side so if you drop the hardware it will fall onto your bench and not inside the K3.

With the K3 on its bottom feet, unplug and remove the KIO3 board (see Figure 5). Rock it while lifting it upward as necessary to “walk” the connectors at the K3 RF board apart.

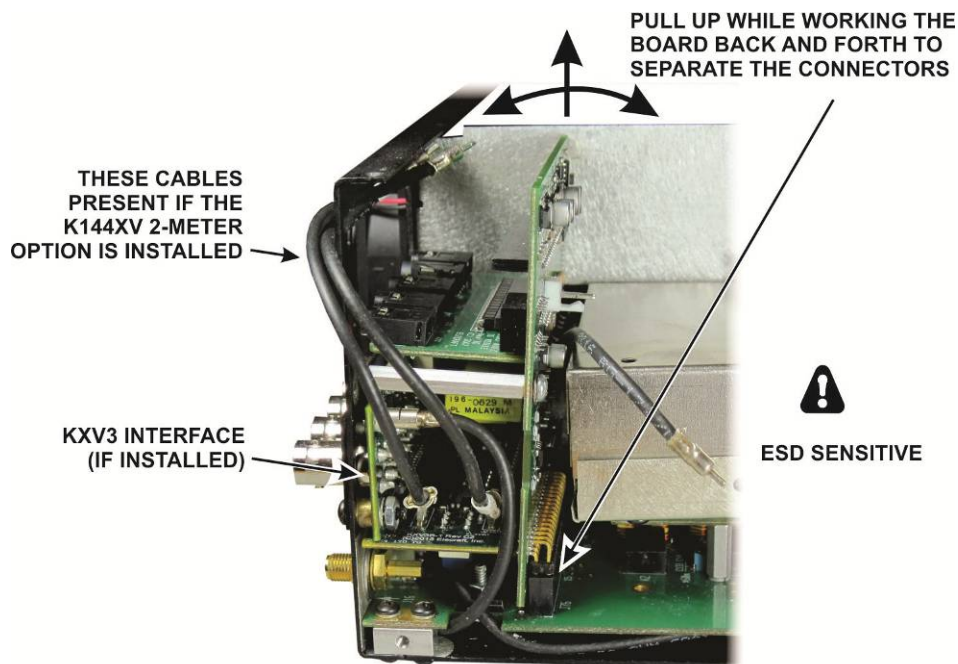

Figure 5. Removing the KIO3 Board.

Remove the standoff from the original KIO3 board and mount it on the KIO3B main board as shown in Figure 6.

Mount the new audio I/O board on the main board as shown in Figure 6. Be sure you don't mix up the new and old audio I/O boards. The new board has part number E850647 near one corner and the connector pins. (Another part number is shown between the multi-pin connector and the jacks. Look for the correct number near one corner of the board.)

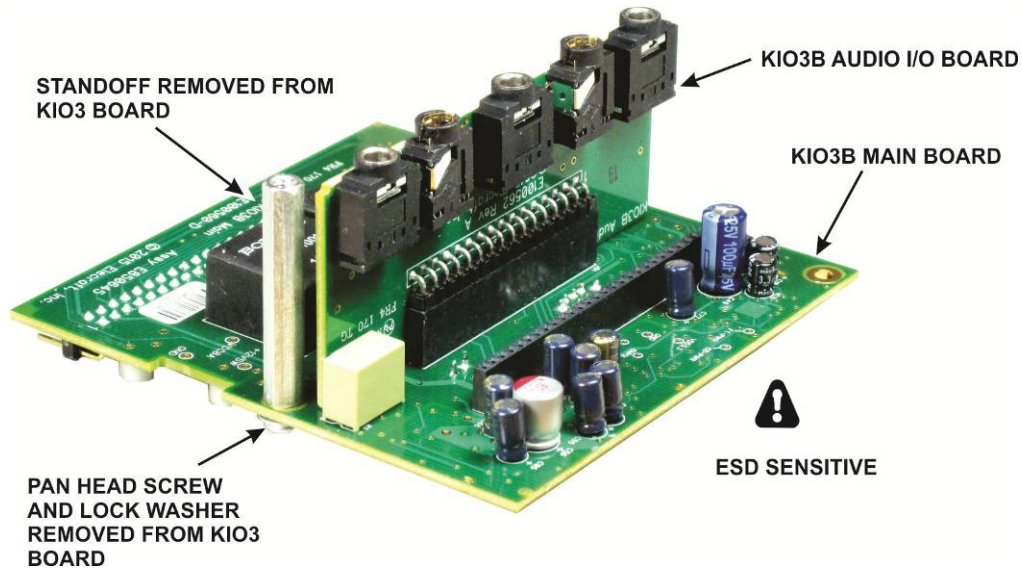

Figure 6. Mounting the Standoff and Audio I/O Board on the KIO3B Main Board.

Plug the KIO3B main board into the J76 on the K3 RF board (the same connector used by the original KIO3 board, see Figure 5). Be sure all the pins engage the connector.

Mount the upper standoff you removed from the original KIO3 board in the same location on the KIO3B main board, using the original screw and lock washer (see Figure 4).

Plug the new digital I/O board into the remaining connector on the KIO3B main board as shown in Figure 7. Be sure all the pins engage and the connectors are fully seated.

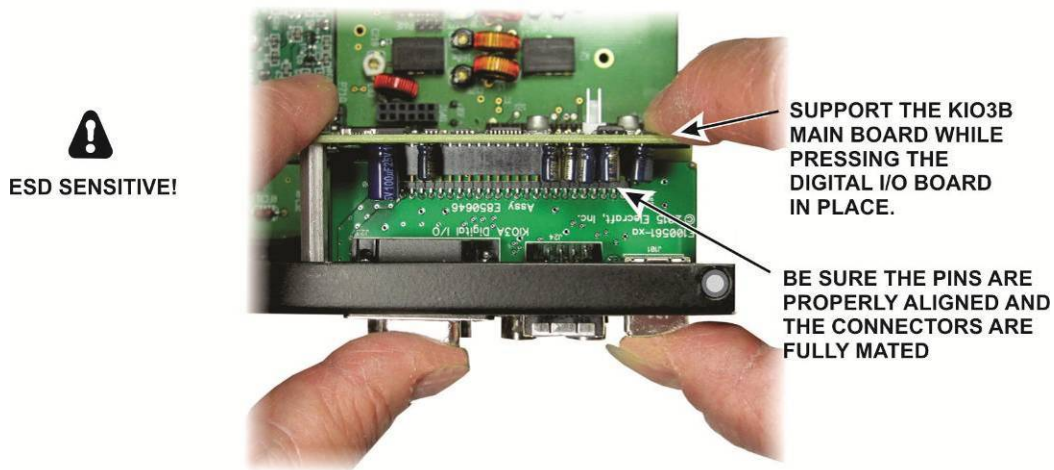

Figure 7. Installing the KIO3 Digital I/O Board.



Mount the new digital I/O panel as shown in Figure 8. Do not tighten the screws or jack screw nuts until they have all been started on their threads and the connectors are aligned in the panel cutouts.

**⚠ Do not over-tighten the jack screw nuts. Too much torque can twist the hex head off of the threaded shaft.**

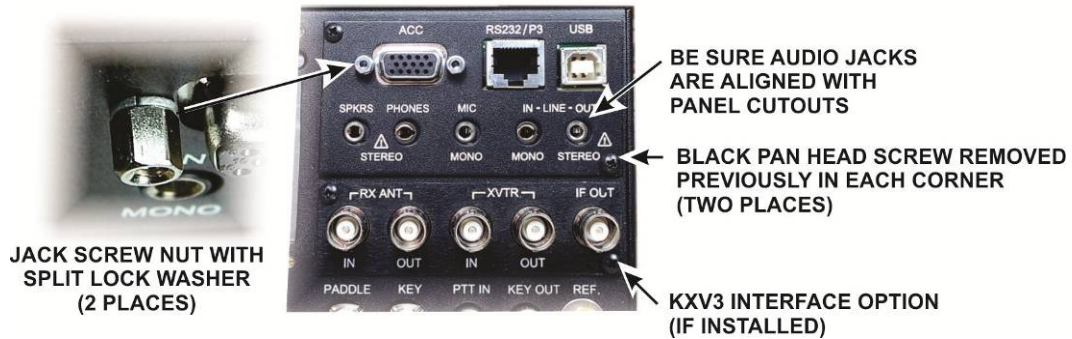

Figure 8. Mounting the new KIO3B Rear Panel Cover.

Turn the K3 so you can see the component side of the KIO3B main board and locate the USB/RS232 switch (see Figure 9). Place the switch in the USB/RS232 position as shown (toggle to the right looking at the switch). This switch is used if you ever need to force a firmware load and have only a USB interface to your personal computer (see *Forcing a Firmware Download Using the USB Interface* on page 13).

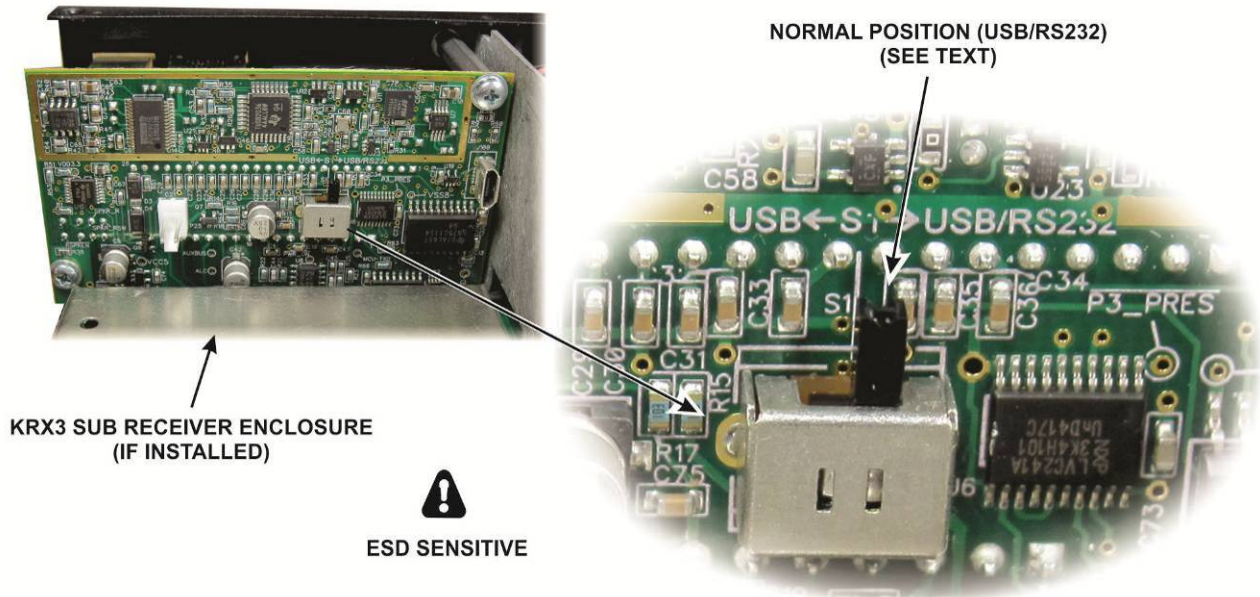

Figure 9. KIO3B USB/RS232 Switch.

- Replace the side panel on the K3 (see Figure 2 on page 6). If the K144XV is installed:
    - Be sure the two TMP cables have not pulled loose from the KXV3 module (see Figure 10). Note the location of the marked TMP cable.
    - Carefully dress the cables into the notch in the KIO3B main board as shown in Figure 10.
    - As you install the side panel, keep the cables above the K144XV module where you can reach the ends to replace them in the K144XV connectors after the side panel is in place.
- i Hint:** Stand the K3 on its side feet as you did to remove the panel and hold tension on the two TMP cables for the K144XV to keep them in the notch while you put the side panel in place. Then hold the side panel against the K3 until you have replaced at least two of the screws to be sure the cables do not slip out of the notch.
- Reconnect the power connector to the K144XV.
  - Reconnect the TMP cables to the K144XV module. For reference, complete cabling diagrams are shown in Appendix A.

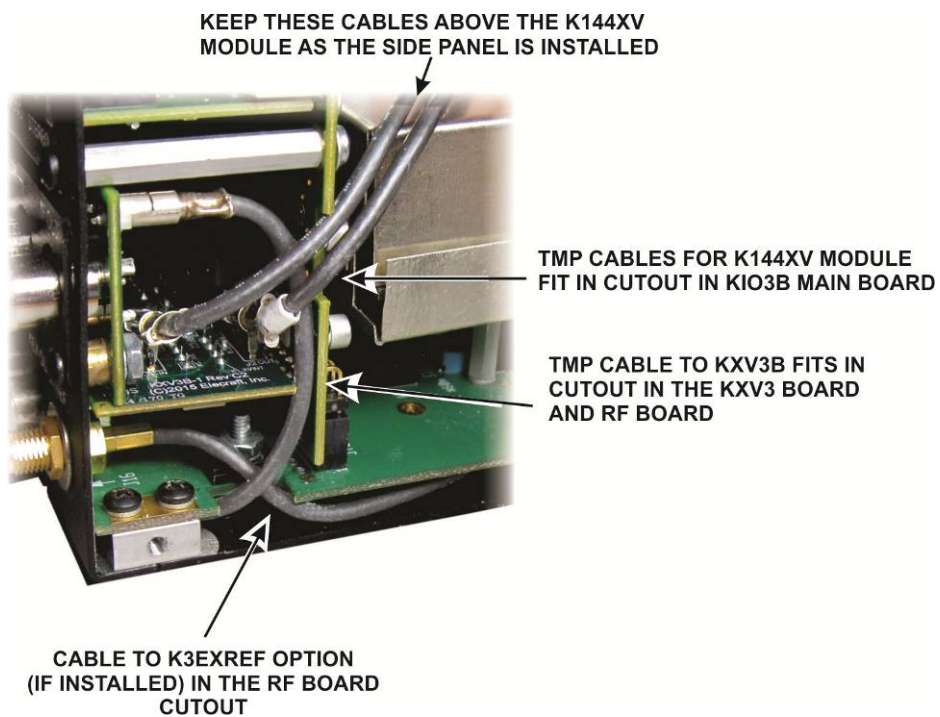

Figure 10. Positioning the TMP Cables in Preparation for Installing the Side Panel.

☐ If the K144XV 2-meter option and KRX3 sub receiver are installed be sure the 12V power cable is routed as shown in Figure 11 so the cable is not trapped between the speaker and top of the sub receiver enclosure.

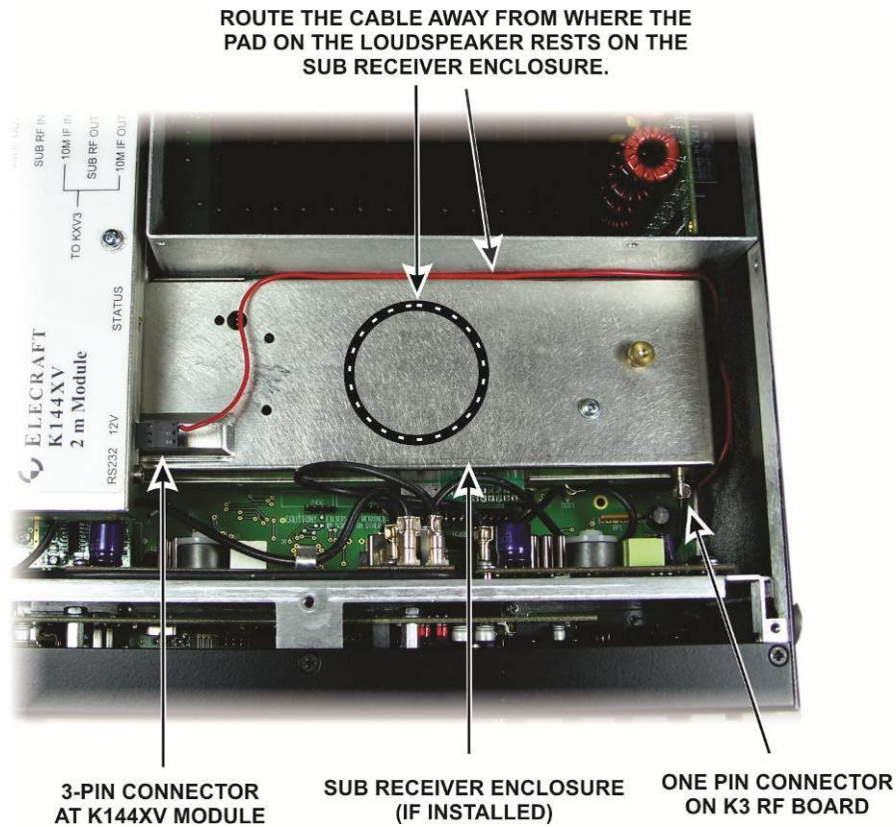

Figure 11. K144XV Power Cable Routing.

☐ Replace the top cover (see Figure 1 on page 5). Connect the speaker to the KIO3B main board as shown in Figure 12.

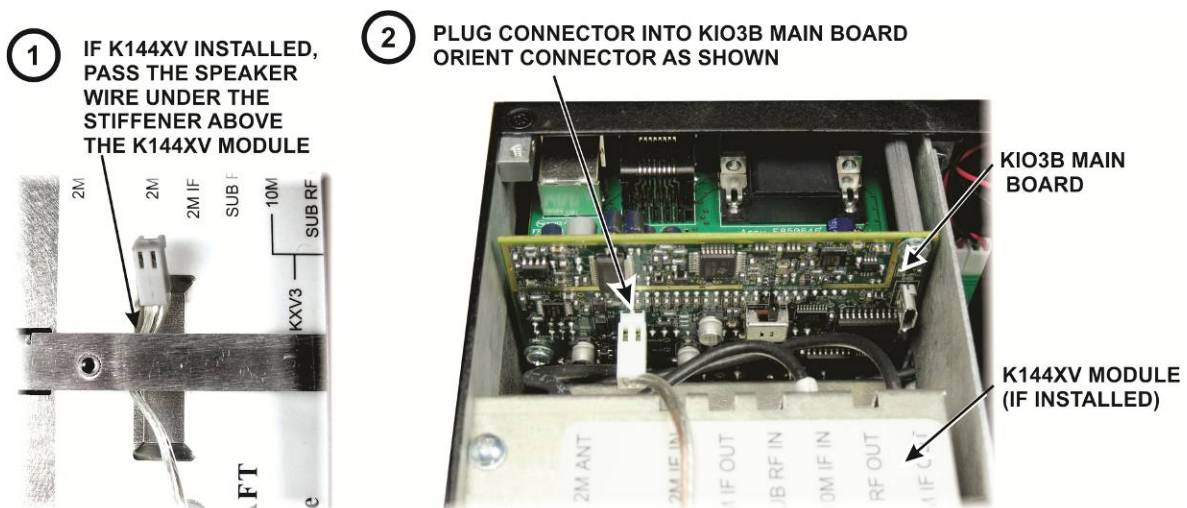

Figure 12. Connecting the Speaker Cable to the KIO3B Board.

## Initial Setup

Connect your K3 to power and tap **POWER** to turn it on.

Check to ensure the K3 recognizes the new KIO3B board as follows. Hold **CONFIG** to enter the configuration menu and turn  $\odot$  **B** (VFO B) to locate **KIO3B** on the LCD. The presence of the letter B indicates the K3 has recognized the new KIO3 board.

Check proper operation of the speaker and phones logic:

- Hold **CONFIG** to enter the configuration menu and turn  $\odot$  **B** (VFO B) to locate **SPKR+PH** on the LCD.
- Turn the  $\odot$  **A** (VFO A) knob so **no** is displayed on the LCD.
- Check to see if audio is present in the speaker with phones unplugged. If not tap the **1** switch on the keypad until you see **PH.R SW -** on the LCD (be sure the - sign is displayed at the end). This is the default setting required with the KIO3B installed that restores normal operation; Selecting **no** will silence the speaker when phones are plugged in and if **yES** is selected both phones and speaker will be active at the same time.

## Computer Interface

You can use a USB connection to your pc with the supplied USB A-B cable connected to the USB port on the KIO3B or you can continue to use an RS232 connection with the supplied cable connected to the RS232/USB port on the KIO3B.

### USB Computer Interface

To use the USB connection between the K3 and your pc, hold **CONFIG** to enter the configuration menu and turn  $\odot$  **B** to locate **RS232** on the LCD. Turn  $\odot$  **A** (VFO A) to display **USb** on the VFO A display. If your pc is turned on, it will power up the USB interface and recognize the KIO3B USB port even if the K3 is turned off or the configuration is not properly set. You must set the configuration to **USb** before your pc can communicate with the K3 itself.

**⚠ Some pc operating systems will assign the sound card in the KIO3B as the default sound device. Check your pc to be sure KIO3B is not the default sound device to avoid inadvertently transmitting various pc alert sounds on the air.**

## ***Forcing a Firmware Download Using the USB Interface***

Normally you will update firmware using the USB interface just as you have previously with the RS232 interface. However, if you encounter a problem and must force a firmware download as described in your K3 Owner's Manual while using the USB interface to your pc, you must temporarily throw a switch on the KIO3B board to activate the USB port. Otherwise the logic will automatically try to use the RS232 port. The switch is shown in Figure 9 on page 9.

- Remove the K3 top cover and place the **USB <-> USB/RS232** switch on the KIO3B main board in the **USB** position.
- Return the switch to **USB/RS232** position after completing the download.

**⚠ The switch must be in the USB/RS232 position for RS232 communications to work properly. For example, not all features on the P3 Panadapter such as the frequency display will work unless the switch is in the USB/RS232 position.**

## **RS232 Computer Interface**

If using the RS232 connection between the K3 and your computer, hold **CONFIG** to enter the configuration menu and turn **⊖ B** to locate **RS232** on the LCD. Turn **⊖ A** (VFO A) to display the desired baud rate on the VFO A display. You must choose **38400 b** when connecting to a P3 Panadapter (see below).

## **P3 Panadapter Interface**

Figure 13 shows the connections for a P3 Panadapter using the cable supplied with the KIO3B. The baud rate must be set to 38,400 as described under *RS232 Computer Interface* above. The RS232 connection between the P3 and your computer is not changed. As before, you can adjust the baud rate between the P3 and your pc using the P3's menu.

If desired you can connect your K3 to a computer with a USB port as shown in Figure 14, but to maintain full functionality of the P3 interface you will need the special cable shown in the figure. Order cable CBLP3Y. Set the RS232 baud rate to **USb** as described under *USB Computer Interface* above.

## **Monitoring RS232 Data**

If you have a device such as a STEPP-IR antenna controller or pc program that monitors the RS232 port, you can continue to use it with the USB port active.

You can connect your device to the RS232 data in two ways:

- Use the RJ-45 to DE-9S cable plugged into the RS232/USB port on the K3 and sense the RS232 signals at the DE-9S connector.
- If you have a P3 Panadapter connected to the K3, sense the RS232 signals at the connection to the PC connector on the P3. **Never attempt to sense RS232 signals at the XCVR connector.**

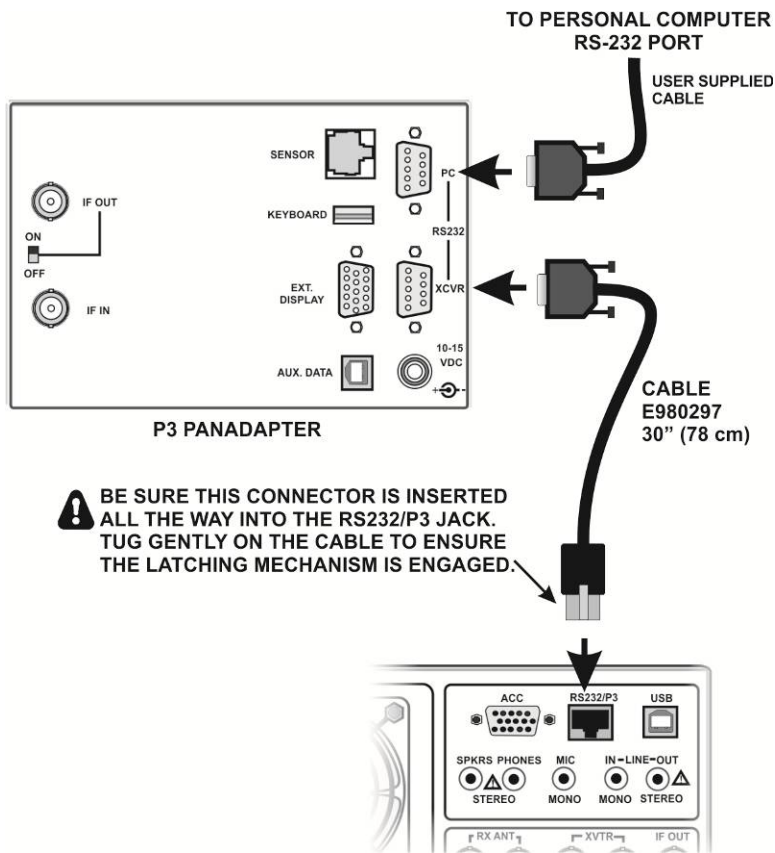

Figure 13. P3 Cabling for RS232 Computer Interface.

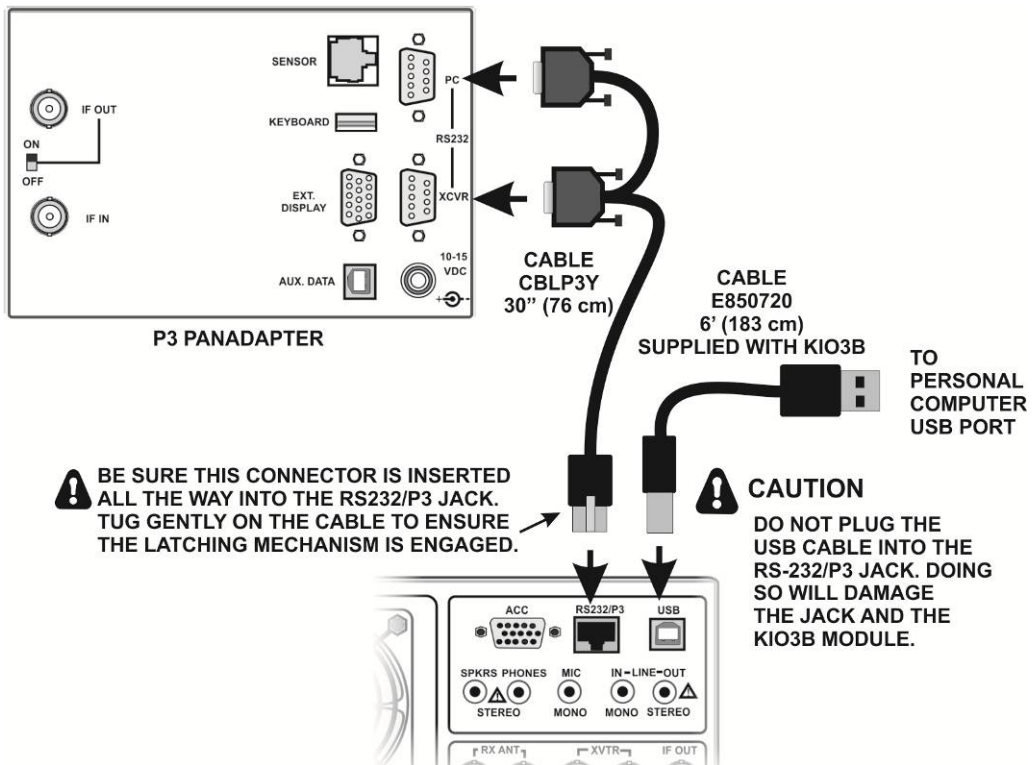

Figure 14. P3 Panadapter Cabling for USB Computer Interface.

# Customer Service and Support

## **Technical Assistance**

You can send e-mail to [support@elecraft.com](mailto:support@elecraft.com) and we will respond quickly - typically the same day Monday through Friday. Telephone assistance is available from 9 A.M. to 5 P.M. Pacific time (weekdays only) at 831-763-4211. Please use e-mail rather than calling when possible since this gives us a written record of the details of your problem and allows us to handle a larger number of requests each day.

## **Repair / Alignment Service** (*We want to make sure everyone succeeds!*)

If necessary, you may return your Elecraft product to us for repair or alignment. (Note: We offer unlimited email and phone support to get your kit running, so please try that route first as we can usually help you find the problem quickly.)

**IMPORTANT: You must contact Elecraft before mailing your product** to obtain authorization for the return, what address to ship it to and current information on repair fees and turn around times. (Frequently we can determine the cause of your problem and save you the trouble of shipping it back to us.) Our repair location is different from our factory location in Aptos. We will give you the address to ship your kit to at the time of repair authorization. *Packages shipped to Aptos without authorization will incur an additional shipping charge for reshipment from Aptos to our repair depot.*

## **Elecraft 1-Year Limited Warranty**

This warranty is effective as of the date of first consumer purchase. It covers both our kits and fully assembled products. For kits, before requesting warranty service, you should fully complete the assembly, carefully following all instructions in the manual.

**What is covered:** During the first year after date of purchase (or if shipped from factory, date product is shipped to customer), Elecraft will replace defective or missing parts free of charge (post-paid). We will also correct any malfunction to kits or assembled units caused by defective parts and materials. Purchaser pays inbound shipping to us for warranty repair, we pay shipping to return the repaired equipment to you by UPS ground service or equivalent to the continental USA and Canada. Alaska, Hawaii and outside U.S. and Canada actual return shipping cost paid by owner.

**What is not covered:** This warranty does not cover correction of kit assembly errors. It also does not cover misalignment; repair of damage caused by misuse, negligence, or builder modifications; or any performance malfunctions involving non-Elecraft accessory equipment. The use of acid-core solder, water-soluble flux solder, or any corrosive or conductive flux or solvent will void this warranty in its entirety. Also not covered is reimbursement for loss of use, inconvenience, customer assembly or alignment time, or cost of unauthorized service.

**Limitation of incidental or consequential damages:** This warranty does not extend to non-Elecraft equipment or components used in conjunction with our products. *Any such repair or replacement is the responsibility of the customer. Elecraft will not be liable for any special, indirect, incidental or consequential damages, including but not limited to any loss of business or profits.*

## Appendix A – K144XV Cabling

The following diagrams are provided to help you properly reconnect your K144XV two meter option after installing the KIO3B.

- If you have a K144XV without the optional K144XV Ref Lock installed, see Figure 15.
- If you have the optional K144XV Ref Lock installed and your K3 has the original synthesizers (with a large toroidal inductor near the center, see Figure 16
- If you have the optional K144XV Ref Lock installed and your K3 has the new KSYN3A synthesizers installed, see Figure 17.

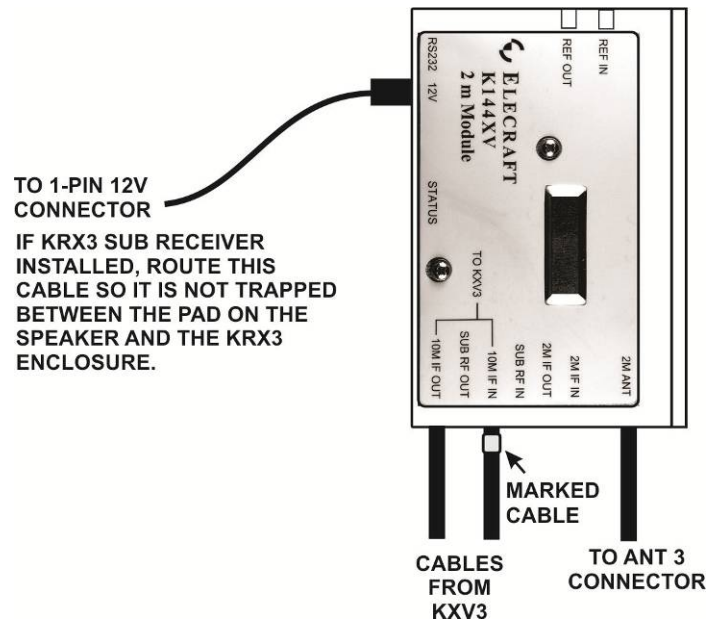

Figure 15, Basic K144XV Cabling (No K144XV Ref Lock).



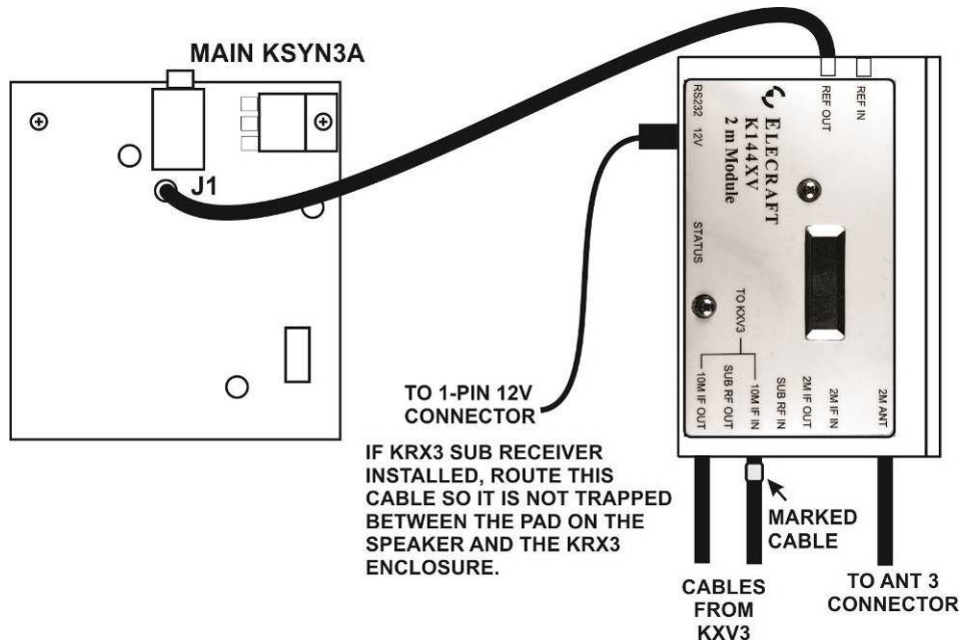

Figure 16. K144XV Cabling with KSYN3A and K144 Ref Lock.

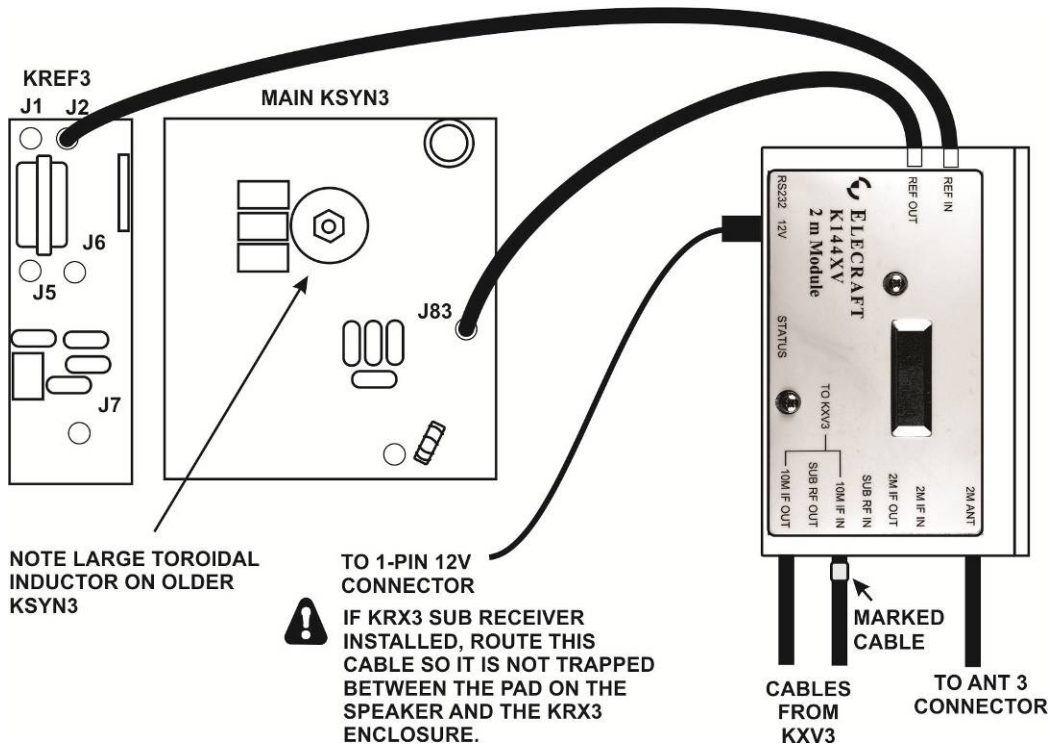

Figure 17. K144XV with K144XV Ref Lock and Original Synthesizers.